

# t-Rex 3200 (long version, focus rotational speed)

## I-44-89-L12 S2



### Description

14-pole BLDC motor with high-performance neodymium magnets and three digital Hall sensors to detect the rotor position. The electrical connections are designed as a plug-in system. Additional power electronics are required to operate the motor. Motor design with a hollow shaft is also available upon request. This allows the cables to run through the motor or the implementation of output on both sides.

### Special feature

- Designed with **focus on rotational speed**
- Enormous performance density – 3 times stronger than motors of comparable size
- High overload resistance
- Ideally suited as direct drive, or generator for gearless applications
- Special winding upon request
- Design and manufacture of motor to specified operating point is possible

3200.00-0004 with shaft

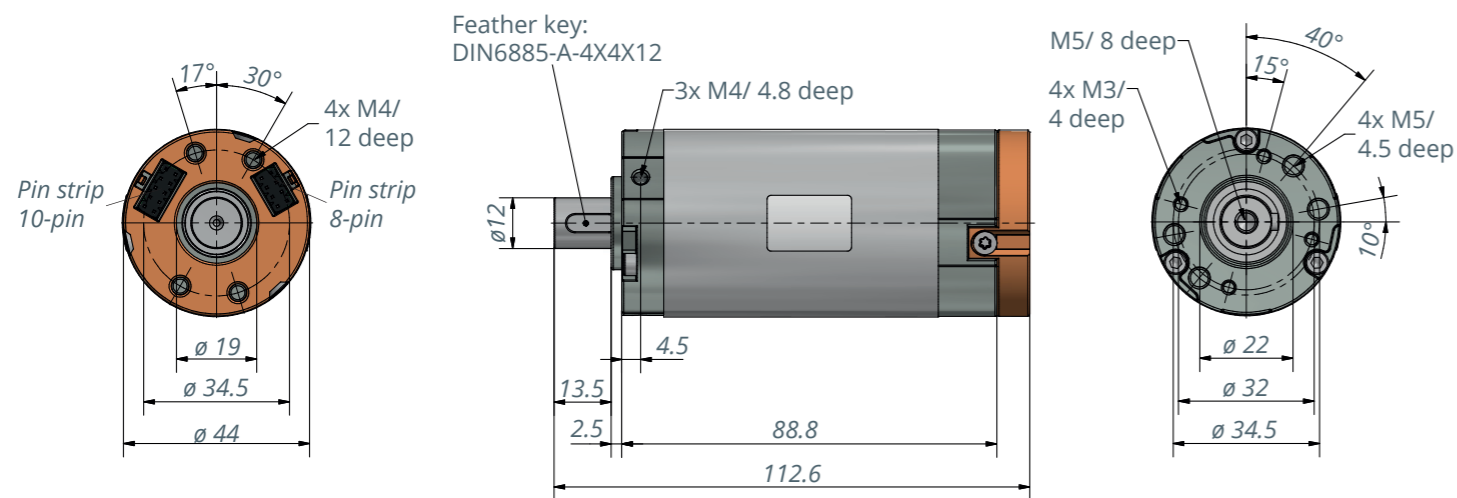

Motor cable approx. 1.5 m

Item number: 3200.53-05

t-Rex 3200 I-44-89 L12 S2 DH	3200.00-0004	
Rated voltage	24 VDC	36 VDC
Rated current	4.0 A	4.0 A
Rated torque	0.3 Nm	0.2 Nm
Rated speed	2418 rpm	3767 rpm
Shaft power (output)	67 W	79 W
Max. efficiency	74 %	76 %
Idle speed	2680 rpm	4053 rpm
No-load current	0.55 A	0.56 A
Stall torque	2 Nm	2 Nm
Starting current at idle speed	22.7 A	21.6 A
Torque constant	0.09 Nm/A	0.09 Nm/A
Speed constant	112 rpm/V	113 rpm/V

### Motor parameters

Terminal resistance (phase to phase)	27 Ohm
Terminal inductance (phase to phase)	45 mH
Rotor inertia	26.5 kg* mm <sup>2</sup>
Number of poles	14
Interconnection of the motor	Star
Number of coils per phase	2
Interconnection of coils	2 Series
Direction of rotation	bidirectional

Note: Max. ambient temperature = 40 °C, controller-specific  
At the nominal point (TU = 20°C), controller-specific

### Motor characteristics at 24 V

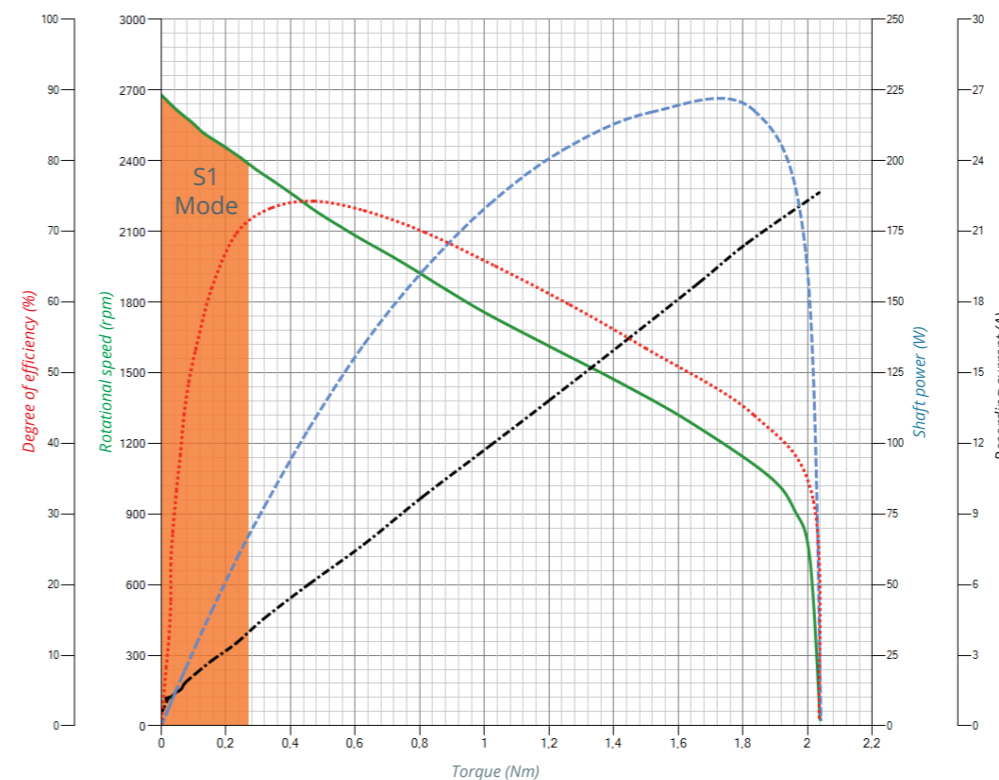

### Motor phases

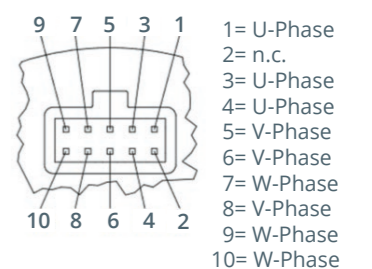

n.c.= please do not connect  
RM 2,54 / 10 PIN  
W+P 3491-10

### Hall-Sensors

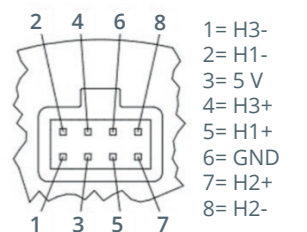

Socket strip RM 2.54 / 8 PIN  
W+P 3491-08

### Digitale Hall-Sensoren

Supply of sensors: Voltage range: 4.5 to 5.5 V DC, Optional: voltage regulator for 5 V, Input current: < 70 mA

Output signals of sensors: Differential output (RS422 standard, datasheet AM26 C31-TI)

Typical voltage range: 0.2/ 3.4 V @ 20 mA, Output current: max. 20 mA

Signal structure: The Hall sensors have a 120° phase shift to each other. Due to the 14-pole design the

Signal frequency is seven times higher than the speed